

ESCO PINS

PART NO	DESCRIPTION	MACHINE MODEL	DIAMETER	LENGTH
3310802	Snubber Pin Lock Pin	72", 80", 82", 84", 86", 100" 104" Grapple	3/4"	3"

NOTE: *Grease adjustable & not grease adjustable type snubbers*

ASSOCIATED PARTS:

OEM NUMBERS: ESC 4034855, ESC 422527, TBJ 841467700



3310800	Tong Cylinder Pin	72", 100" Grapple	1 1/2"	4 3/8"
---------	-------------------	-------------------	--------	--------

NOTE: *Recessed hole for grease fitting - No heat treat*

ASSOCIATED PARTS: *Grease fitting 3600683; 3/8"-16UNC X 3 1/4" Bolt; 3/8"-16UNC Locknut*

OEM NUMBERS: ESC 4010460, ESC 420356, ESC 418913, TBJ 841463800, TRE 32213

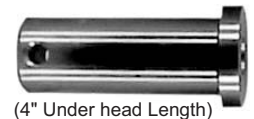

3310809	Tong Cylinder Pin	86", 100", 104" Grapple	2"	4 7/8"
---------	-------------------	-------------------------	----	--------

NOTE: *Recessed hole for grease fitting; Drilled for banjo lock pin*

ASSOCIATED PARTS: *Grease fitting 3600683; Banjo lock pin 4035149; Bolt 1/2"-13UNC X 1 1/2"; 1/2" Lockwasher*

OEM NUMBERS: ESC 4049401, ESC 435638, ESC 435755, TBJ 841941300

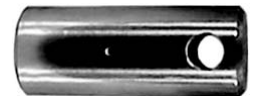

3310812	Tong Cylinder Pin	80", 84", 100", 104" Grapple	2"	4 7/8"
---------	-------------------	------------------------------	----	--------

NOTE: *Recessed hole for grease fitting; Drilled to release grease at mid point of pin; Drilled for 10 mm spiral lock pin; Finish ground; Heat treat*

ASSOCIATED PARTS: *Spiral pin 4095898; (M10 x 100); Grease fitting 3600683*

OEM NUMBERS: ESC 4129482, ESC 4095896, TBJ 843104900, TBJ F434916

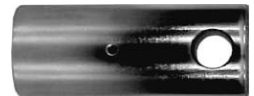

3310811	Tong Cylinder Pin	110", 120" Grapple	2"	7 1/4"
---------	-------------------	--------------------	----	--------

NOTE: *Recessed hole for grease fitting; Drilled to release grease 3 1/8" from grease fitting end of pin; Drilled for 10 mm spiral lock pin; Finish ground; Heat treated*

ASSOCIATED PARTS: *Spiral pin 4095898; (M10 x 100); Grease fitting 3600683*

OEM NUMBERS: ESC 4085281, TBJ F434201



ESCO PINS

PART NO	DESCRIPTION	MACHINE MODEL	DIAMETER	LENGTH
3310805	Yoke/Snubber Pin	72", 82", 86", 100", 104" Grapple	2"	12 1/2"

NOTE: 2"-12UNF threads; 3/4" hole opposite end of the threads for lock pin; Heat treated; Finish ground; Plated; Grease adjustable & not grease adjustable type snubbers; Drilled to accept cotter pin to lock castellated nut

ASSOCIATED PARTS: Lock pin 4034855; Spacer 4095818; Acorn nut 4105141; or Castellated nut 4035128

OEM NUMBERS: ESC 4032651, ESC 435308, ESC 435246, ESC 425827, TBJ 841467500, TRE 32223



3310810	Yoke/Snubber Pin	72", 82", 86", 100", 104" Grapple	2"	12 1/2"
---------	------------------	-----------------------------------	----	---------

NOTE: 2"-12UNF threads; 3/4" hole opposite end of the threads for lock pin; Heat treated; Finish ground; Plated; Grease adjustable & not grease adjustable type snubbers; Is not drilled to accept cotter pin to lock castellated nut

ASSOCIATED PARTS: Lock pin 4034855; Spacer 4095818; Acorn nut 4105141

OEM NUMBERS: ESC 4105142, TBJ 841499900



3310808	Yoke/Snubber Pin	72", 82", 86", 90", 100", 104" 110", 120" Grapple	2"	13 1/2"
---------	------------------	------------------------------------------------------	----	---------

NOTE: 2"-12UNF threads; 3/4" hole opposite end of the threads for lock pin; Heat treated; Finish ground; Plated; Grease adjustable, Sorting & Bunching Head snubber; Is not drilled to accept cotter pin to lock castellated nut

ASSOCIATED PARTS: Lock pin 4034855; Spacer 4126308; Acorn nut 4095818

OEM NUMBERS: CAT 125-0123, ESC 4105140, ESC 4095616, TGC 93594, TBJ 843112600



3310807	Tong Pin	86", 100" 104" Grapple	2"	15"
---------	----------	------------------------	----	-----

NOTE: 2"-12UNF threads 2" long; 3/4" hole opposite end of the threads for banjo lock pin; Finish ground; Heat treated

ASSOCIATED PARTS: Banjo lock pin 4039260; Lockwasher 3/4"; Bolt 3/4"-10UNC x 1 1/2"; Pin nut 2"-12UNF

OEM NUMBERS: ESC 4095028, ESC 4038878, ESC 435629, ESC 435284, TBJ 842896000, TBJ 841720500

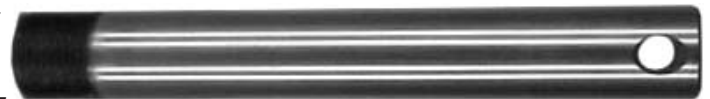

FRANKLIN PINS

PART NO	DESCRIPTION	MACHINE MODEL	DIAMETER	LENGTH
3271000	Dozer Blade Cylinder	Models: XL, XL-N; 185	1 1/4"	3 7/8"

NOTE: "D" shaped head; Opposite end drilled for lock pin; Mild steel no heat treat
 ASSOCIATED PARTS: 1/4"x 2" Cotter pin, 1 1/4" Flat washer

OEM NUMBERS: FRK 001-1019



3291000	Steering Cylinder	132XL, 130A/XL, 132A/XL, 142A/XL	1 1/4"	5 3/8"
---------	-------------------	----------------------------------	--------	--------

NOTE: 7/8"-14NF threads; "D" shaped head; Mild Steel no heat treat
 ASSOCIATED PARTS: 1500354 Pin nut (7/8" Nylock); 1500353 Flat washer (7/8" Hardened);
 1511560 Self aligning bushing (1 1/4" ID)

OEM NUMBERS: FRK 1503020, FRK 027-1027, FRK 027-1070



3251000	Hinge/Center Section	132XL, 130A/XL, 132A/XL, 142A/XL	2"	6"
---------	----------------------	----------------------------------	----	----

NOTE: "D" shaped head; 2"-12UNF threads; Threaded end drilled & tapped for grease fitting;
 Ground finish; Heat treated
 ASSOCIATED PARTS: 1508615 Pin nut; 1510437 Double sealed self aligning bushing (2" ID)

OEM NUMBERS: FRK 001-1037

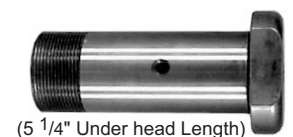

3251003	Hinge/Center Section	170XLN, 185, 170PAB	2 1/2"	7 13/16"
---------	----------------------	---------------------	--------	----------

NOTE: 2"-12UNF threads; Recessed hole for grease fitting; Head of pin has slot for locking;
 Ground finish; Heat treated
 ASSOCIATED PARTS: 1508615 Pin nut; 2001010 Double sealed self aligning bushing (2 1/2" I.D.)

OEM NUMBERS: FRK 1004561



HYDRO AX PINS

PART NO	DESCRIPTION	MACHINE MODEL	DIAMETER	LENGTH
---------	-------------	---------------	----------	--------

3234001	Hinge Center Section	311B, 311B II, 411, 411B II, 511B, 511B II, 611B, 611B II	2 1/4"	7"
---------	----------------------	--------------------------------------------------------------	--------	----

NOTE: Washer under welded on head; 1 1/2"-12UNF threads; Recessed hole for grease fitting

ASSOCIATED PARTS: 8551998 Grease fitting; 8669996 Pin nut; 8815977 Self aligning bushing (2 1/4"ID)

OEM NUMBERS: HYA 8050027, HYA 1020074



3234000	Hinge Center Section	311B, 311B II, 411, 411B II, 511B, 511B II, 611B, 611B II	2 5/8"-2 1/4"	8"
---------	----------------------	--------------------------------------------------------------	---------------	----

NOTE: Screw on head welded in place after installation; Head has 6 bolt holes to bolt to frame; 1 1/2"-12UNF threads; Recessed hole for grease fitting

ASSOCIATED PARTS: 8551998 Grease fitting; 8669996 Pin nut; 8815977 Self aligning bushing (2 1/4"ID)

OEM NUMBERS: HYA 8050026, HYA 1020073



3374001	Lift Cylinder, Tilt Cylinder Tilt Cylinder Link Arm	311B, 411B, 411B II	1 1/2"	9 1/8"
---------	--------------------------------------------------------	---------------------	--------	--------

NOTE: 1 1/4"-12UNF threads; Mild steel no heat treat

ASSOCIATED PARTS: 8359410 Pin nut; 8815992 Self aligning bushing (1 1/2" ID)

OEM NUMBERS: HYA 8051164



JOHN DEERE PINS

API PART NO	DESCRIPTION	MACHINE MODEL	DIAMETER	LENGTH
3290602	Steering, Blade, Arch & Boom Cylinder	540E-548E, 640E-648E, 740E-748E, 540G-548G thru 540G III-548G III; 640G-648G thru 640G III-648G III; 740G-748G thru 740G III-748G III	1 49/64"	5 1/8"

NOTE: One end drilled for 15mm bolt Finish ground & plated

ASSOCIATED PARTS: AT157173 Self aligning bushing; 14M7319 Locknut & T142262 Capscrew

OEM NUMBERS: DER T147990; DER AH202070

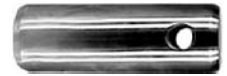

3290601	Steering Cylinder	340D, 440C, 440D-448D, 540, 540A, 540B, 540D-548D, 640, 640D-648D	1 3/4" - 1 1/2"	5 1/8"
---------	-------------------	-------------------------------------------------------------------	-----------------	--------

NOTE: 1 7/8" hex head; Grease fitting hole in threaded end of the pin; 1 1/4"-12UNF

ASSOCIATED PARTS: T27821 Pin nut; AT61453 Self aligning bushing; 2182900 Grease fitting straight 1/8" NPT

OEM NUMBERS: DER T59402



(4 7/8" Under head Length)

3230600	Hinge/Center Section Bottom	340D, 440C, 440D-448D, 540B, 540D-548D, 640, 640D-648D	2"	5 3/8"
---------	-----------------------------	--------------------------------------------------------	----	--------

NOTE: Welded on head 3" wide X 4 3/4" long, drilled for bushing & lock bolt; Drilled in head end for grease fitting; Heat treated & plated

ASSOCIATED PARTS: JD7781 Grease fitting; T43913 or T113331 Bushing; E19344 (2) Grease seal

OEM NUMBERS: DER AT113989; DER AT42790



(5" Under head Length)

3290600	Steering Cylinder	340D, 440C, 440D-448D, 540B, 540D-548D, 640, 640D-648D	1 3/4" - 1 1/2"	5 7/16"
---------	-------------------	--------------------------------------------------------	-----------------	---------

NOTE: Weld on teardrop shaped pin lock to head of pin; Grease fitting hole in head end of the pin; 1 1/4"-12UNF

ASSOCIATED PARTS: T27821 Pin nut self aligning bushing; AT61453; T162396 Grease Fitting Straight 1/8" NPT

OEM NUMBERS: DER AT66633; DER T55578



(4 7/8" Under head Length)

3230605	Hinge Center Section Bottom	540E-548E, 540G-548G, 540G-II, 548G-II, 640E-648E, 640G-648G, 640G-II, 648G-II, 740E-748E, 740G-748G, 748G-II if Field Articulation Kit AT190709 has been installed S/N's 57347 and down 540G-II, 540G-III, 548G-II, 548G-III, 640G-II, 640G-III, 648G-II, 648G-III, 748G-II, 748G-III S/N's 57348 & up, 360D, 460D, 560D	5 1/8" - 3 3/20" 130mm-80mm	6 1/8"
---------	-----------------------------	---------------------------------------------------------------------------------------------------------------------------------------------------------------------------------------------------------------------------------------------------------------------------------------------------------------------------	--------------------------------	--------

NOTE: (3) Thru drilled holes 12, 4, & 8 o'clock; Thru holes threaded at head end of pin

ASSOCIATED PARTS: AT175578 Self aligning bushing; T184607 Steel bushing; T184605 Steel bushing; 40M7293 Snap ring; AT178191 Seal

OEM NUMBERS: DER T184606



(4" Under head Length)

JOHN DEERE PINS

PART NO	DESCRIPTION	MACHINE MODEL	DIAMETER	LENGTH
---------	-------------	---------------	----------	--------

3230604	Hinge/Center Section	540G-548G	3" - 2 1/2"	6 7/8"
----------------	----------------------	-----------	-------------	--------

NOTE: (3) Thru drilled holes: 12, 4, & 8 o'clock; Thru holes threaded at head end of pin

ASSOCIATED PARTS: AT61251 Self aligning bushing; T184853(2) Grease seal

OEM NUMBERS: DER T184599



3230601	Hinge/Center Section	340D, 440C, 440D-448D, 540B, 540D-548D, 640, 640D-648D	1 7/16"	7"
----------------	----------------------	-----------------------------------------------------------	---------	----

NOTE: Weld on lock tab on head of pin; 1 1/4"-12UNF threads; Threaded end drilled for spiral pin; (6.3 X 63mm)

ASSOCIATED PARTS: Spiral pin (6.3 X 63mm); 14H927 Pin nut

OEM NUMBERS: DER AT83003; DER AT42789



3230603	Hinge/Center Section Bottom (early models)	540E-548E, 640E-648E, 740E-748E, 540G-548G, 640G-648G, 740G-748G	70mm (approximately 2.753")	7 45/64"
----------------	-----------------------------------------------	---------------------------------------------------------------------	--------------------------------	----------

NOTE: Weld on head with slot for lock bolt & bushing - Heat treated and plated

ASSOCIATED PARTS: 19M7720 Capscrew; T146246 Washer; 28H3401 Bushing; 14M7291 Flange nut

OEM NUMBERS: DER AT167601

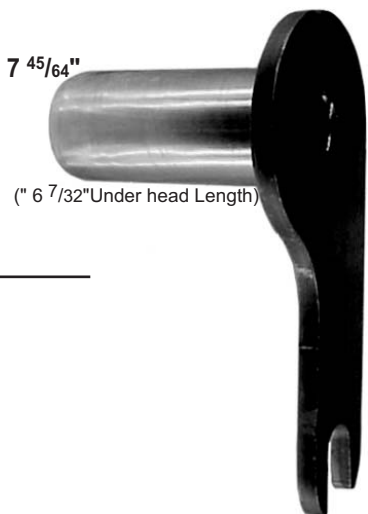

3230602	Hinge/Center Section Top (early models)	540E-548E, 640E-648E, 740E-748E, 540G-548G, 640G-648G, 740G-748G	3" - 2 1/2"	10"
----------------	--------------------------------------------	---------------------------------------------------------------------	-------------	-----

NOTE: Weld on lock tab on head of pin; 2-12UNF threads; Drilled in thread end for grease fitting; Heat treated and plated

ASSOCIATED PARTS: JD7781 90° Grease fitting; T27294 Pin nut; AT61251 Self aligning bushing; T184853 (2) Grease seal

OEM NUMBERS: DER AT117170

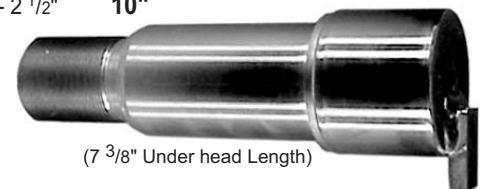

RANGER PINS

PART NO	DESCRIPTION	MACHINE MODEL	DIAMETER	LENGTH
3295100	Arch Cylinder	666D, 667C, 667D, F665, F666, F667, F65, F66, F67	1 3/4"	4 1/4"
	Boom Cylinder	666D, 667D, F666, F667, F66, F67		
	Dozer Blade Cylinder	664D, 666D, 667D, F665, F666, F667, F65, F66, F67		
	Grapple Cylinder	665D, 666C, 666D, F665, F666, F65, F66		
	Steering Cylinder	664D, 666D, 667D, F665, F666, F667, F65, F66, F67		

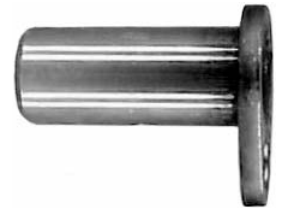

NOTE: Recessed hole for grease fitting; Welded on tear drop shaped head with a 7/8" hole for locking
 ASSOCIATED PARTS: R1574466 Bushing

OEM NUMBERS: RGR R12574706, RGR R1939294, RGR R12929380, RGR R252980

3230300	Arch Cylinder	664C, 666C, 667C	1 3/4"	5 1/8"
	Boom & Tie Rod	667C		
	Boom Cylinder	667C, 667D		
	Cradle/Walking Beam	662, 664, 666		
	Dozer Blade	662, 664, 664B, 664C, 666, 666B, 666C, 667C		
	Dozer Blade Cylinder	662, 664, 664B, 664C, 666, 666B, 666C, 667C		
	Grapple Cylinder	666C		
	Hinge/Center Section	664, 664B, 664C, 666, 666B, 666C		
	Steering Cylinder	662, 664, 664B, 664C, 666, 666B, 666C, 667C		



NOTE: 1/2" hole drilled at one end for banjo lock pin; Recessed hole in the end of the pin for a grease fitting; Ground finish & heat treated

ASSOCIATED PARTS: Banjo lock pin R586452; Self aligning bushing R1574466; Grease fitting 10H000025; Thrust Washer 200327; Shim 1901079

OEM NUMBERS: RGR R1915205, RGR R1900158

3230301	Hinge/Center Section	664, 664B, 666, 666B, 666C, 667	1 3/4"	5 5/16"
---------	----------------------	---------------------------------	--------	---------

NOTE: 1/2" hole drilled at one end for banjo lock pin; Drilled for grease fitting in opposite end; Washer welded on grease fitting end; Ground finish & heat treated

ASSOCIATED PARTS: Banjo lock pin R586452; Self aligning bushing R1574466; Grease fitting 10H000025; Thrust washer 200327; Shim 1901079

OEM NUMBERS: RGR R1915214, RGR R1911805

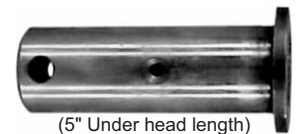

3230302	Cradle/Walking Beam	664, 664B, 666, 666B, 667	1 3/4"	5 11/32"
	Hinge/Center Section	667		

NOTE: 3 1/2" diameter "D" shaped 4 bolt flange head; 2 holes 1/2" - 10 & 2 holes drilled 17/32"; Grease fitting head end of pin; Ground finish & heat treated

ASSOCIATED PARTS: Self aligning bushing R1574466; Grease fitting 10H000025; Thrust washer 200327; Shim 1901079

OEM NUMBERS: RGR R1919897

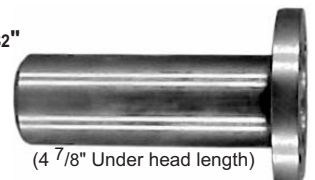

RANGER PINS

PART NO	DESCRIPTION	MACHINE MODEL	DIAMETER	LENGTH
3230304	Arch Pin	664B, 664D, 665D, 666C, 666D, F665, F666, 667, 667C, 667D, F65, F66	2"	5 1/2"
	Boom Pin	667, 667C, 667D		
	Cradle Walking Beam	668, 668B		
	Dozer Blade	668, 668B, 668C, 668D		
	Dozer Blade Cylinder	668, 668B, 668C		
	Grapple Cylinder	664B, 664C, 664D, 666B, 666C, 667		
	Hinge/Center Section	668, 668B		
Steering Cylinder	668, 668B, 668C			



NOTE: Drilled at one end for banjo lock pin; Recessed hole in the end of the pin for a grease fitting; Drilled to release grease 1 3/4" below the grease fitting; Ground finish & heat treated

ASSOCIATED PARTS: Banjo lock pin R586452; Self aligning bushing R1573309; Grease fitting 10H000025

OEM NUMBERS: RGR R1903262

32315101	Yoke/Snubber	665D, 666C, 666D, 667D, F665, F65	1 1/4" threaded end 1 3/4" wear surface	6 5/16"
----------	--------------	-----------------------------------	--------------------------------------------	---------

NOTE: Thread end 1 1/4"-12UNF; 0.140 cotter pin hole; 1/4" lock pin hole in 1 1/4" diameter part of pin

ASSOCIATED PARTS: 1935436 Pin nut

OEM NUMBERS: RGR R1935452



(3 7/16" Wear surface length)

3235106	Cradle/Walking Beam	666D, F666, 667C, 667D, F667, F66, F67	2"	6 13/32"
	Hinge/Center Section	666D, F666, 667C, 667D, F667, F66, F67		

NOTE: Recessed hole in head end of the pin for grease fitting; 5" diameter 8 hole flange head; 6 holes drilled 9/16" located @ 2, 4, 6, 8, 10, & 12 o'clock; 2 holes 5/8"-11 located @ 3 & 9 o'clock

ASSOCIATED PARTS: Self aligning bushing 1923922; Grease fitting 10H000025

OEM NUMBERS: BAR 76320006, RGR R1923916

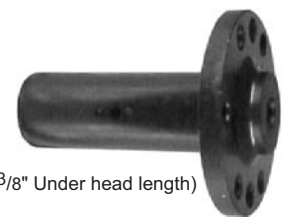

(5 3/8" Under head length)

3230303	Cradle/Walking Beam	664C, 666C	1 3/4"	6 5/8"
	Dozer Blade	666D, F666, 667D, F667, F66, F67		

NOTE: 4 bolt flange, 4 1/8" diameter "D" shaped head; 2 holes 1/2"-10; 2 holes drilled 17/32"; Grease fitting head end of pin

ASSOCIATED PARTS: Self aligning bushing R1574466; Grease fitting 10H000025; Thrust washer 200327; Shim 1901079

OEM NUMBERS: RGR R1920461

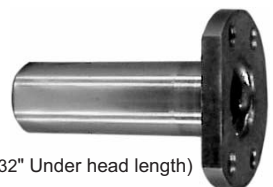

(5 5/32" Under head length)

RANGER PINS

PART NO	DESCRIPTION	MACHINE MODEL	DIAMETER	LENGTH
---------	-------------	---------------	----------	--------

3315102	Yoke/Snubber	F665, F666, F667, F65, F66, F67	1 1/4" threaded end 2" wear surface	6 3/4"
----------------	--------------	---------------------------------	----------------------------------------	---------------

NOTE: Thread end 1 1/4"-12UNF; 0.140 cotter pin hole; 1/4" lock pin hole in 1 1/4" diameter part of pin
ASSOCIATED PARTS: 1935436 Pin nut

OEM NUMBERS: RGR R1937947



3235108	Cradle/Walking Beam Hinge/Center Section	664D, 665D, F665, F65 664D, 665D, F665, F65	1 3/8"-2 1/2" taper 2 1/4" straight boss	7 3/8"
----------------	---------------------------------------------	------------------------------------------------	---------------------------------------------	---------------

NOTE: Threads 1 1/4"-12UNF; Taper to fit frame; Straight boss to fit bushing; Hole in boss end of pin for extraction 3/4"-10UNC

ASSOCIATED PARTS: R1930810 Pin nut; R1519195 Wiper seal; R1564693 Bushing; 203529 O-ring

OEM NUMBERS: RGR R1933003, RGR R1930811

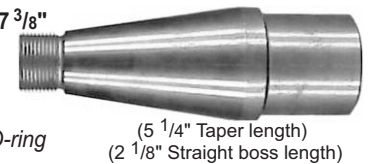

3235107	Cradle/Walking Beam Hinge/Center Section	664D, 665D, F665, F65 664D, 665D, F665, F65	1 3/8"-2 1/2" 1st taper 2 1/8"-1 7/8" 2nd taper	8 5/16"
----------------	---------------------------------------------	------------------------------------------------	----------------------------------------------------	----------------

NOTE: Threads 1 1/4"-12UNF; 1st taper to fit frame; 2nd taper to fit bushing;
Threads on bushing end 1 9/16"-18UNF

ASSOCIATED PARTS: R1930810 Pin nut; R1519195 Wiper seal; R1930566 Bushing; R1935537 Pin nut

OEM NUMBERS: RGR R1933002

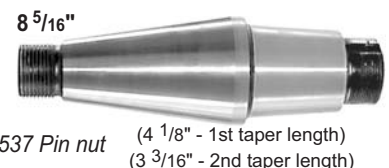

TIMBERJACK PINS

PART NO	DESCRIPTION	MACHINE MODEL	DIAMETER	LENGTH
3280801	Dozer Blade Cylinder	360, 460, 560, 660	45 mm (approximately 1 49/64")	5 1/8"
	Single Arch Cylinder	360, 460, 560		
	Dual Arch Cylinder	560, 660		



NOTE: Recessed hole for grease fitting and recess threaded for pin extraction. Drilled to release grease at mid point of pin, Ground finish & heat treated Drilled for lock pin in each end

ASSOCIATED PARTS: (2) 811705800 Spiral pin; F015250 Self aligning bushing

OEM NUMBERS: TBJ 827265800

3292902	Dozer Blade Cylinder	225, 230, 240, 350, 380, 450, 480, 480T, 520	1 3/4"	5 1/8"
	Steering Cylinder	240, 350, 380, 450, 480, 480T, 520		
	Single Arch Cylinder	240		
	Dual Arch Cylinder	380, 450		
	Boom Cylinder	380, 450		

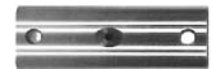

NOTE: Recessed and threaded hole for pin extraction; Drilled to release grease at mid point of pin; 3/8" hole drilled at each end of wear surface; Ground finish & heat treated; Will substitute for 822702300

ASSOCIATED PARTS: 810000100 Grease fitting; Spiral lock pin 810065800 (3/8" x 3") or (3/8"-16 UNC x 3 1/2" & 3/8"-16UNC Locknut rod end); 3/8" x 1" base end; Wear washer 821602800; Self aligning bushing 810282000

OEM NUMBERS: TBJ 825482400; TBJ 822623000; TBJ 822930800

3292900	Dozer Blade Cylinder (early models)	350,380, 450, 480, 480T, 520	1 3/4"	5 1/8"
	Steering Cylinder (early models)	200, 205, 207, 208, 215, 225, 230, 240, 350, 380, 450, 480, 480T, 520		



NOTE: Recessed hole for grease fitting and recess threaded for pin extraction; Drilled to release grease at mid point of pin; Ground finish & heat treated

ASSOCIATED PARTS: 810000100 Grease fitting; Spiral lock pin 810065800 (3/8" x 3") or (3/8"-16 UNC x 3 1/2" & 3/8"-16UNC Locknut rod end); 3/8" x 1" base end; Wear washer 821602800; Self aligning bushing 810282000

OEM NUMBERS: TAM 80877959; TBJ 822702300; TBJ 821839200; TBJ 850024700

3272900	Dozer Blade / Dozer Blade Cylinder	200, 205, 207, 208, 215, 225, 230, 240	1 5/8"	5 1/8"
---------	---------------------------------------	----------------------------------------	--------	--------



NOTE: Drilled at one end for spiral pin; Recessed hole in the end of the pin for a grease fitting; Drilled to release grease at mid point of pin; Mild steel, no heat treat

ASSOCIATED PARTS: Spiral lock pin 3342901 (3/8" x 3"); 810000100 Grease fitting

OEM NUMBERS: TBJ 820006700

TIMBERJACK PINS

PART NO	DESCRIPTION	MACHINE MODEL	DIAMETER	LENGTH
3292904	Steering Cylinder	360, 460, 560, 660	1 49/64"	5 9/16"

NOTE: Snap ring groove in OD; Hole for 10mm bolt or spiral pin under snap ring groove
 ASSOCIATED PARTS: 811359900 Snap ring; M10 X 1.50-100 Bolt; M10 X 1.50 Locknut; or 811705800 Spiral pin; Self aligning bushing 810282000

OEM NUMBERS: TBJ 826913200



3292903	Steering Cylinder	380, 450, 480, 480T	1 3/4"	5 5/8"
---------	-------------------	---------------------	--------	--------

NOTE: Recessed hole for grease fitting; Snap ring groove in OD same end as grease fitting; Hole for 3/8" lock bolt or spiral pin opposite end of snap ring groove
 ASSOCIATED PARTS: 811017900 Grease fitting; 811359900 Snap ring; 3/8"-16UNC X 3 1/2" Lock bolt, 3/8"-16UNC Locknut or 810065800 Spiral pin; 810282000 Bushing

OEM NUMBERS: TBJ 826509800



3280802	Single Arch	240, 350, 380, 450, 480, 520	2 1/2"	5 3/4"
	Dual Arch	380, 450, 480, 480T, 520		
	Boom	380, 450, 480, 480T, 520		

NOTE: 3/4"-10 hole drilled in end of pin for extraction; 17/32" hole in same end as 3/4"-10 hole for lock bolt
 Associated Parts: 1/2"-13UNC X 4 Bolt; 1/2"-13UNC Locknut; 810757000 Bushing

OEM NUMBERS: TBJ 826078800; TBJ 825017500



3232900	Hinge/Center Section Cradle/Walking Beam	200, 205, 207, 208, 215, 225, 230, 240	1 3/4" wear surface	6 5/16"
---------	---------------------------------------------	----------------------------------------	---------------------	---------

NOTE: Recessed hole in threaded end of pin for grease fitting Threads 1 3/8"-12; Drilled to release grease at mid point of pin; Threaded hole for pin extraction; Ground finish & heat treated
 ASSOCIATED PARTS: 810000100 Grease fitting; 810408000 Lock nut; 81028200 Self aligning bushing; Wear washers: 820032700, 820032800, 820032900, 820033000, OR 825562800, 8255629, 8255630, 825563100, 825563200, 825563300, 825563400, 825563500, 825563600

OEM NUMBERS: TAM 80407089; TBJ 822775100; TBJ 820032200; TBJ 822448600; TBJ 822453500; TBJ 822690400

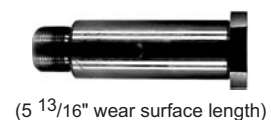

3232902	Hinge/Center Section Cradle/Walking Beam	208, 225, 230, 240	2" wear surface	6 11/16"
---------	---------------------------------------------	--------------------	-----------------	----------

NOTE: Recessed hole in threaded end of pin for grease fitting Threads 1 3/8"-12; Drilled to release grease at mid point of pin; Threaded hole for pin extraction; Ground finish & heat treated
 ASSOCIATED PARTS: 810000100 Grease fitting; 810408000 Lock nut; 810106700 Self aligning bushing; Wear washers: 825562800, 825562900, 825563000, 825563100, 825563200, 825563300, 825563400, 825563500, 825563600

OEM NUMBERS: BLO 3031145; TBJ 823980500

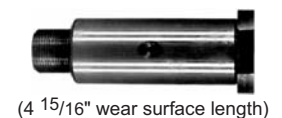

TIMBERJACK PINS

PART NO	DESCRIPTION	MACHINE MODEL	DIAMETER	LENGTH
3232905	Hinge/Center Section Cradle/Walking Beam	240C, 360, 460 360, 460	Refer to Notes	7 1/4"



(2 3/4" taper length)
(2 1/4" straight boss)

NOTE: *DIAMETER: 2 7/32" top of taper, 60mm bottom of taper, 60mm straight boss. -- 1 3/4"-12UNF threads; Recessed hole in threaded end of pin for grease fitting; Tapered for seating in a sleeve; Bushing diameter to allow bushing movement up and down*

ASSOCIATED PARTS: 810000100 Grease fitting (Genuine TBJ uses 841785200 Grease fitting); 810683000 Pin nut; 3952103 Seal; 842116200 Bushing

OEM NUMBERS: NONE

3232903	Hinge/Center Section Cradle/Walking Beam	225, 230, 240, 350, 380, 450, 480, 520 350, 380, 450, 520	Refer to Notes	7 1/4"
---------	---------------------------------------------	--------------------------------------------------------------	----------------	--------



(4 7/8" taper length)

NOTE: *DIAMETER: 2 7/32" top of taper, 2 3/8" bottom of taper & seal area, 3 15/64" ball. -- 1 3/4"-12UNF threads; Recessed hole in threaded end of pin for grease fitting; Tapered for seating in a sleeve; Ball part of pin is the inner race of bushing*

ASSOCIATED PARTS: 810000100 Grease fitting; 810683000 Pin nut; 822929100 Seal; 810682800 Top bushing; old set up & Cartridge kit (double split) 810682900 Bottom bushing (takes 2), 811150500 Bushing (Cartridge kit)

OEM NUMBERS: BLO 30301147; TBJ 825667000; TBJ 822929200

3232904	Hinge/Center Section Cradle/Walking Beam	240C, 360, 460 360, 460	Refer to Notes	7 13/32"
---------	---------------------------------------------	----------------------------	----------------	----------



(2 3/4" taper length)
(2 1/4" ball length)

NOTE: *DIAMETER: 2 7/32" top of taper, 60mm bottom of taper, 3 15/64" ball. -- 1 3/4"-12UNF threads; Recessed hole in threaded end of pin for grease fitting; Tapered for seating in a sleeve; Ball part of pin is the inner race of bushing*

ASSOCIATED PARTS: 810000100 Grease fitting (Genuine TBJ uses 841785200 Grease fitting); 810683000 Pin nut; 3952103 Seal; 811150500 Bushing

OEM NUMBERS: NONE

3352901	Fairlead Arch-Main Roller	208, 225, 230, 240, 350, 380, 450, 480, 480T, 520, 360, 460	2"	14 3/16"
---------	---------------------------	----------------------------------------------------------------	----	----------



NOTE: *Drilled at one end for spiral pin; Mild steel, no heat treat*

ASSOCIATED PARTS: Spiral lock pin 810427100 (3/8" x 4)

OEM NUMBERS: TBJ 821505000

3352900	Fairlead Arch-Side Roller	208, 225, 230, 240, 350, 380, 450, 480, 520, 550, 360, 460, 660	1 3/8"	20 1/8"
---------	---------------------------	--------------------------------------------------------------------	--------	---------



NOTE: *Drilled at one end for spiral pin; Mild steel, no heat treat*

ASSOCIATED PARTS: Spiral lock pin 810065800 (3/8" x 3")

OEM NUMBERS: TBJ 820399200

TREE FARMER PINS

PART NO	DESCRIPTION	MACHINE MODEL	DIAMETER	LENGTH
3273200	Steering Cylinder	ALL	1 1/2"	2 25/32"
<p>NOTE: 2 1/32" hole thru center of pin for 5/8" diameter bolt ASSOCIATED PARTS: 3596 Bushing</p> <p>OEM NUMBERS: TRE 18673</p>				
3233202	Hinge/Center Section	C6D, C7D	1 3/4"	3 5/16"
<p>NOTE: 57/64" hole thru center of pin for 7/8" diameter bolt ASSOCIATED PARTS: 17323 Bushing</p> <p>OEM NUMBERS: TRE 18658</p>				
3233207	Hinge/Center Section	C4C, C4D, C5D	1 1/2" wear surface	4 3/16"
<p>NOTE: Includes 337-052000 nut; 1 1/4"-12UNF threads; Grease fitting hole in thread end of the pin; "D" shaped head; Ground finish & heat treated ASSOCIATED PARTS: 152-010001 Grease fitting; 3596 Bushing</p> <p>OEM NUMBERS: API 3233200; TRE 11632-100; TRE 11632-1; TRE 11632</p>				
3253202	Cradle/Walking Beam	C6D, C6E, C7D, C7T, C8C, FB67	1 3/4"	5 11/16"
<p>NOTE: 1 1/4"-18 threads; Grease fitting hole in thread end of the pin; "D" shaped head; Ground finish & heat treated ASSOCIATED PARTS: 17323 Bushing</p> <p>OEM NUMBERS: TRE 47368</p>				
3233201	Hinge/Center Section	C4D, C5D, C5 Porter	1 5/8" straight boss 1 5/8" top of taper 1 3/8" bottom of taper 1 3/8" straight boss	6 7/16"
<p>NOTE: 1 1/4"-12 UNF threads; Taper to fit bushing; "D" shaped head; Ground finish & heat treated ASSOCIATED PARTS: 70469 Pin nut; 70393 Bottom bushing; 70394 Top bushing</p> <p>OEM NUMBERS: TRE 70388</p>				

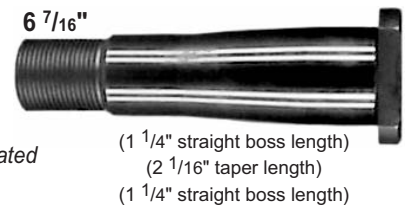
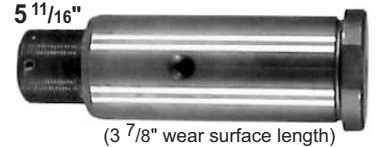
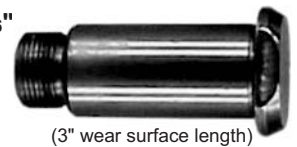
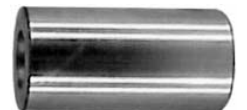

TREE FARMER PINS

PART NO	DESCRIPTION	MACHINE MODEL	DIAMETER	LENGTH
3233205	Hinge/Center Section	C6D, C7D, C7T, FB67,	2 7/16" straight boss 1 7/8" top of taper 1 19/32" bottom of taper 1 37/64" straight boss	9 1/4"



(2 5/16" straight boss length)
(2 3/8" taper length)
(1 9/16" straight boss length)

NOTE: 1 1/2"-12UNF threads; Taper to fit bushing; "D" shaped head; Ground finish & heat treated
ASSOCIATED PARTS:

OEM NUMBERS: TRE 73687

3253200	Cradle/Walking Beam	C4D, C5D	2 1/32" 2" bushing surface	9 7/8"
---------	---------------------	----------	-------------------------------	--------



(4 1/4" wear surface length)
(2 15/16" bushing surface length)

NOTE: 1 1/2"-12UNF threads; Grease fitting hole in thread end of the pin; Step in diameter of wear surface of pin; "D" shaped head; Ground finish & heat treated

ASSOCIATED PARTS: 152-010001 Grease fitting; 3471 Pin nut; 12776 Self aligning bushing (2"ID)

OEM NUMBERS: RGR 10410811; TRE 11834

3253201	Cradle/Walking Beam	C4D, C5D	2 1/32" 2" bushing surface	11 29/32"
---------	---------------------	----------	-------------------------------	-----------



(6 3/4" wear surface length)
(2 15/16" bushing surface length)

NOTE: 1 1/2"-12UNF threads; Grease fitting hole in thread end of the pin; Step in diameter of wear surface of pin; "D" shaped head; Ground finish & heat treated

ASSOCIATED PARTS: 152-010001 Grease fitting; 3471 Pin nut; 12776 Self aligning bushing (2"ID)

OEM NUMBERS: TRE 11835